

## BDPF10-00/X.Y.Z

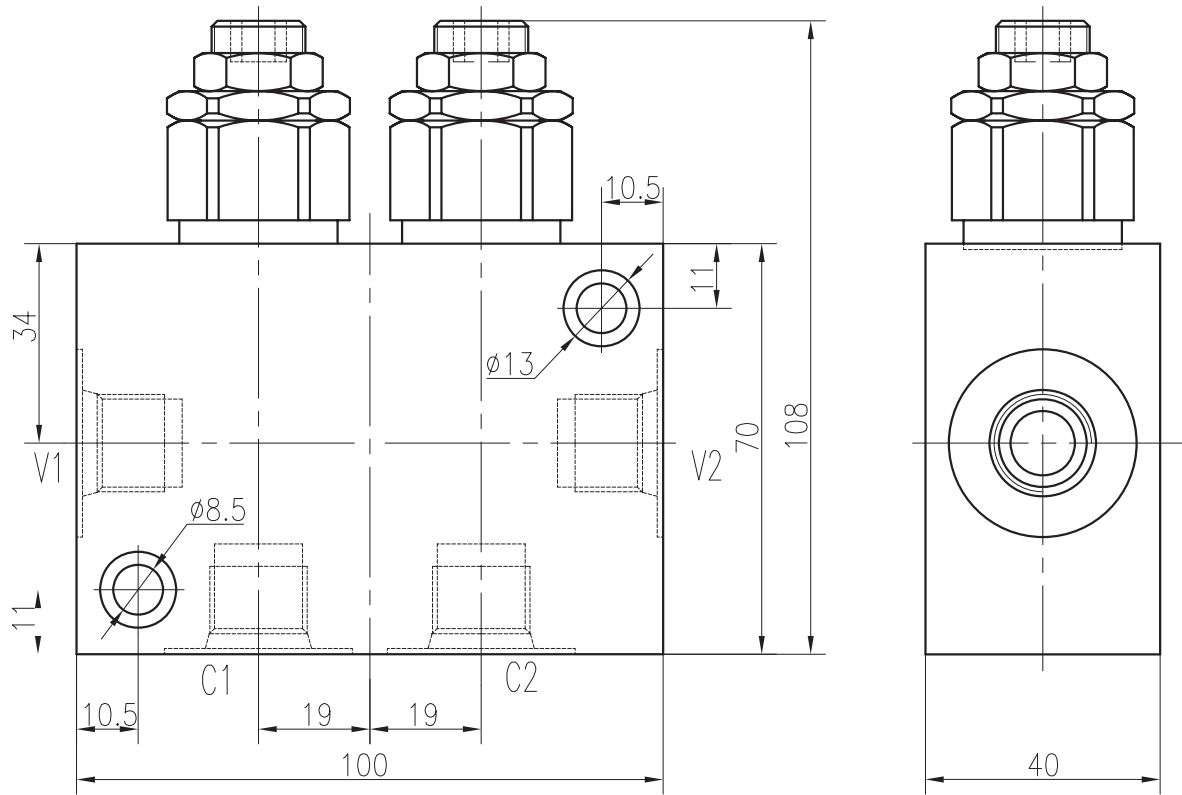

### Specifications:

Max.Working Pressure :	270bar
Flow Max :	60L/min
Internal Leakage :	≤0.4ml/min
Filtration Of Oil :	25μm or better
Temperature :	-30~+110℃ (Standard Buna Seals)
Pilot Ratio :	4.0:1

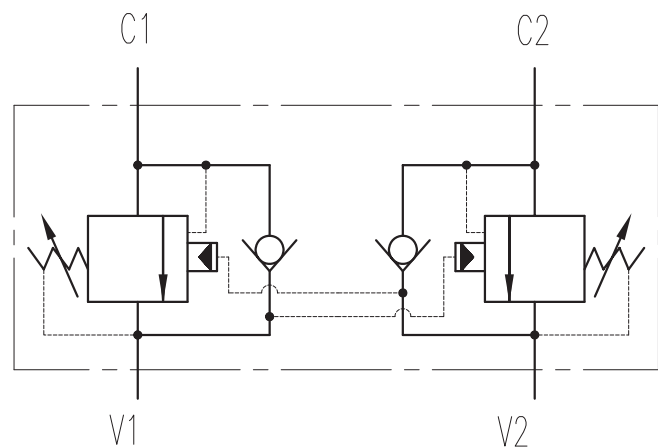

X	PORTING	Y	SEALS
4G	G1/4	N	Buna
8G	G3/8	V	Fluor.
4T	SAE4		
6T	SAE6		

Z	SPRINGS			
	Press. range bar	Press. increase bar/turn	Standard setting bar	Cracking press. bar
05	10~105	22	80	60
10	34~210	38	160	130
15	65~350	64	250	200