

Check Valves(Poppet-type)

BDF08-01/X.Y.Z

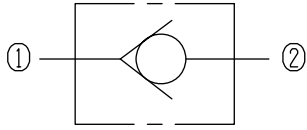

Specifications:

Max working Pressure :	315bar
Flow Max :	30L/min
Internal Leakage :	<0.3ml/min at 210bar
Filtration Of Oil :	25µm or better
Temperature :	-30~+100℃ (Standard Buna Seals)
Cavity :	T4-1
Installation torque :	24.5~27.2Nm
Standard Block Model	T4-11*/13*/14*/16*

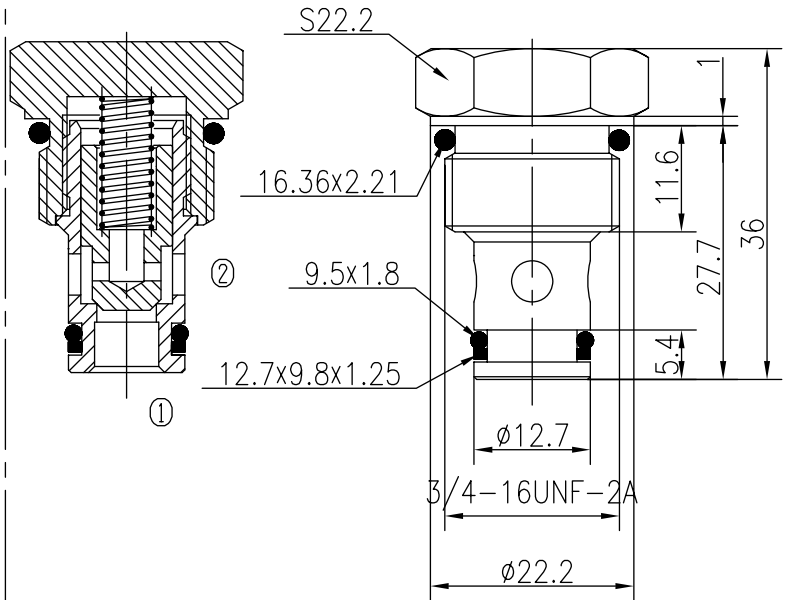

The valve allows flow from ① to ② with very low pressure drop, while blocks flow from ② to ①.

The valve blocks flow from ① to ② until sufficient pressure is applied at ②.

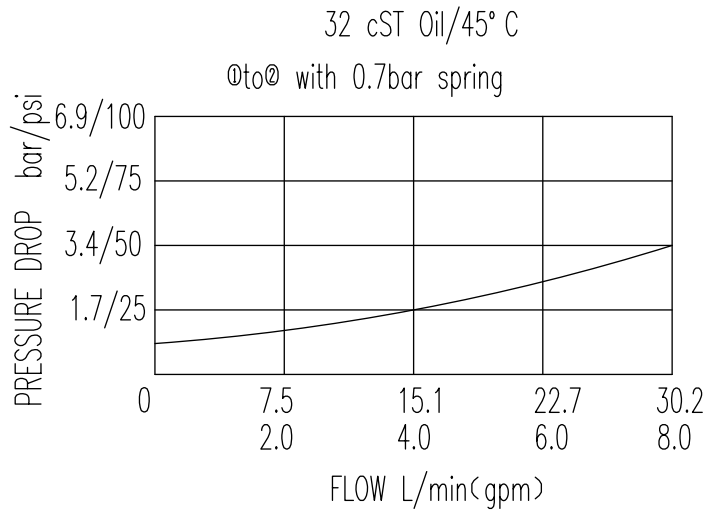

X	PORTING	Y	SEALS
0	Cartridge Only	N	Buna
4G	G1/4	V	Fluor
8G	G3/8		
4T	SAE4		
6T	SAE6		

Z	SPRINGS		
	Cracking Pressure bar		Cracking Pressure bar
05	0.3	25	2.8
10	0.7	30	3.5
15	1.1	35	5.7
20	1.3	40	10.4