

Pilot-operated Relief Valves (Spool-type)

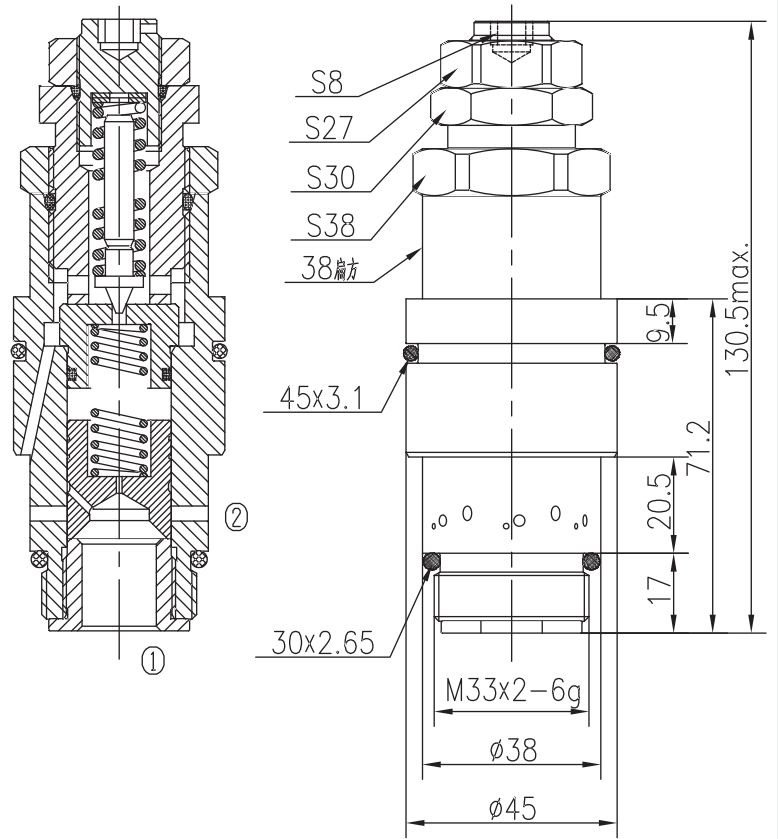

BXYF25-03/X.Y

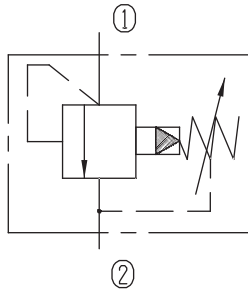

Specifications:

Max working Pressure :	250bar
Flow Max :	200L/min
Internal Leakage :	<300ml/min (85% of Setting Pressure at 30L/min)
Filtration Of Oil :	25 μ m or better
Temperature :	-30~+100 $^{\circ}$ C (Standard Buna Seals)
Cavity :	T-2318
Installation torque :	62.6~73.4Nm

The valve blocks flow from ① to ② until 90% pressure is present at ①. With the continued increase pressure on ①, ② to ③ began to overflow, until to the spring's maximum pressure.

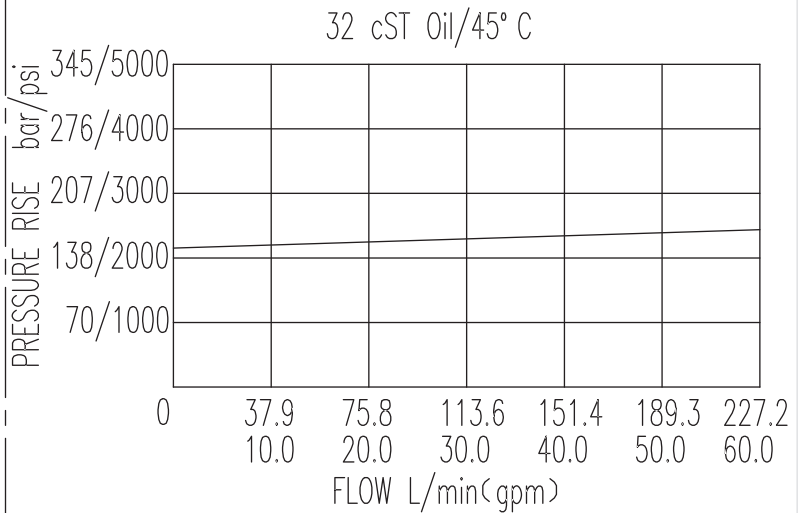

X	ADJUSTMENTS	
03	Leakproof hex. and socket screw	

Y	SPRINGS			
	Press. range bar	Press. increase bar/turn	Standard setting bar	Cracking press. bar
05	80~250		160	146