

Pilot-operated Relief Valves (Poppet-type)

BXYF20-01/X.Y

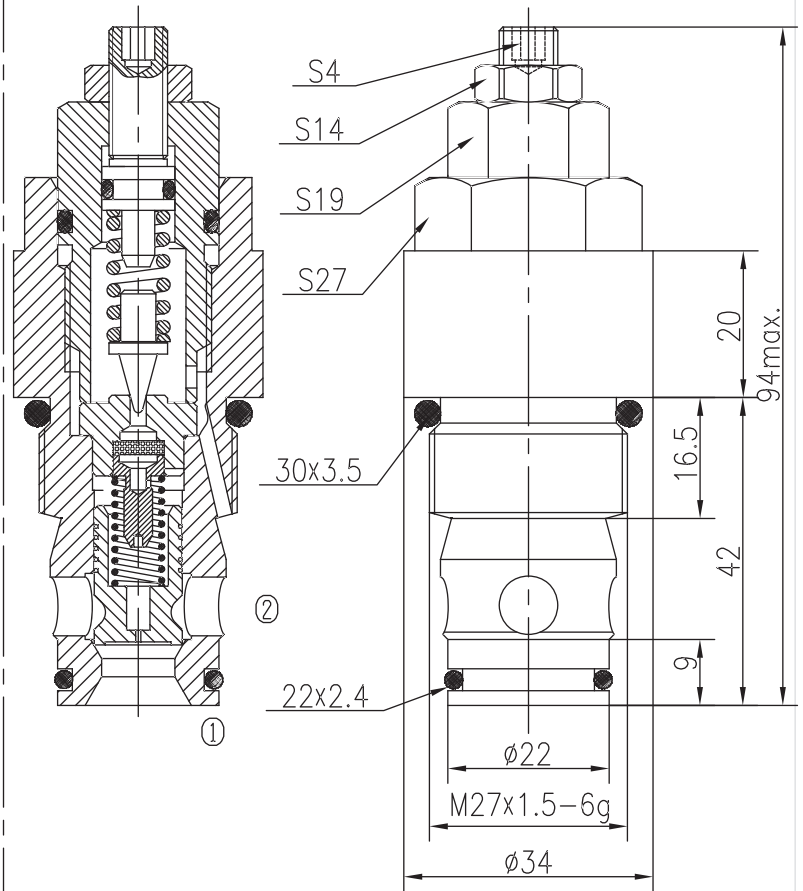
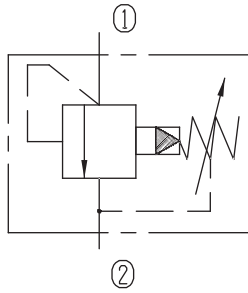

Specifications:

Max working Pressure :	350bar
Flow Max :	113L/min
Internal Leakage :	<30ml/min (85% of Setting Pressure at 30L/min)
Filtration Of Oil :	25µm or better
Temperature :	-30~+100°C (Standard Buna Seals)
Cavity :	T-2310
Installation torque :	44.9~50.3Nm

The valve blocks flow from ① to ② until 90% pressure is present at ①. With the continued increase pressure on ①, ① to ② began to overflow, until to the spring's maximum pressure.

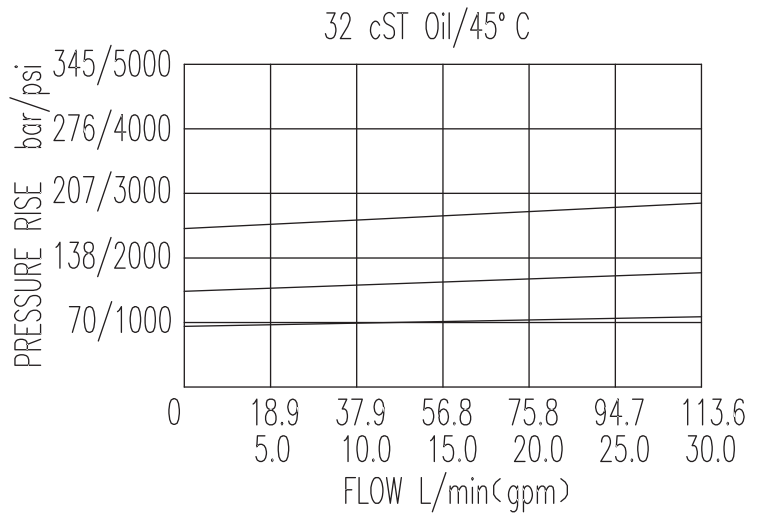

X	ADJUSTMENTS	
03	Leakproof hex. and socket screw	

Y	SPRINGS			
	Press. range bar	Press. increase bar/turn	Standard setting bar	Cracking press. bar
05	16~69	19	60	50
10	81~175	51	120	105
15	148~350	119	180	162