

Pilot-operated Relief Valves (Spool-type)

BXYF16IE-00/X.Y

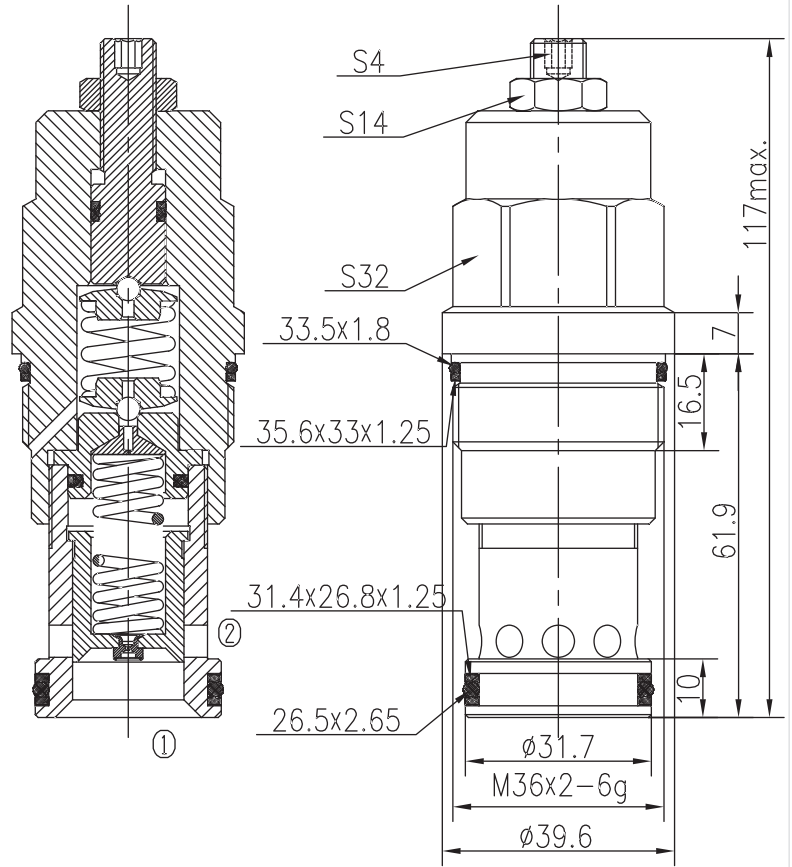
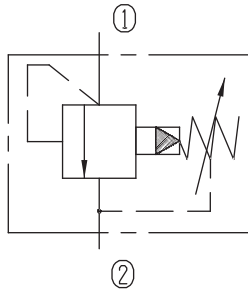

Specifications:

Max working Pressure :	350bar
Flow Max :	300L/min
Internal Leakage :	<120ml/min (85% of Setting Pressure at 30L/min)
Filtration Of Oil :	25µm or better
Temperature :	-30~+100°C (Standard Buna Seals)
Cavity :	T-16A
Installation torque :	200~215Nm

The valve blocks flow from ① to ② until 90% pressure is present at ①. With the continued increase pressure on ①, ① to ② began to overflow, until to the spring's maximum pressure.

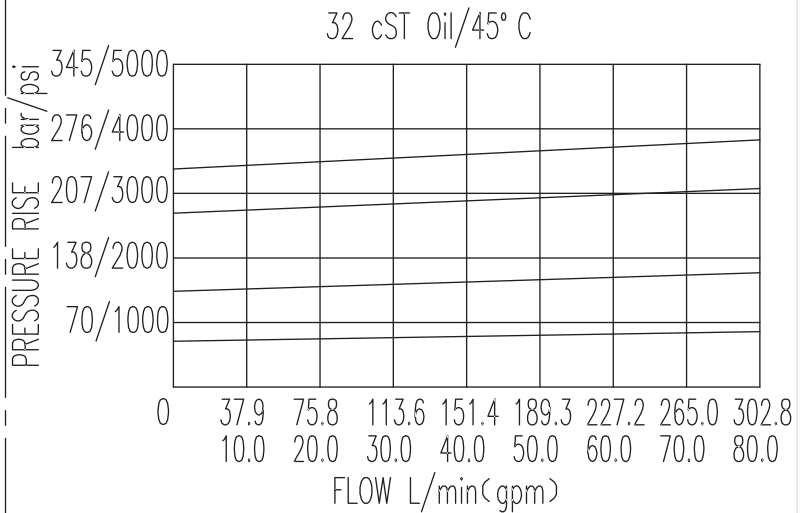

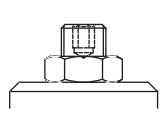
X	ADJUSTMENTS	
03	Leakproof hex. and socket screw	

Y	SPRINGS			
	Press. range bar	Press. increase bar/turn	Standard setting bar	Cracking press. bar
05	19~78	29	60	50
10	55~126	45	120	105
15	116~250	86	210	182
20	175~350	128	250	220