

Pilot-operated Relief Valves (Poppet-type)

BXYF10-04/X.Y

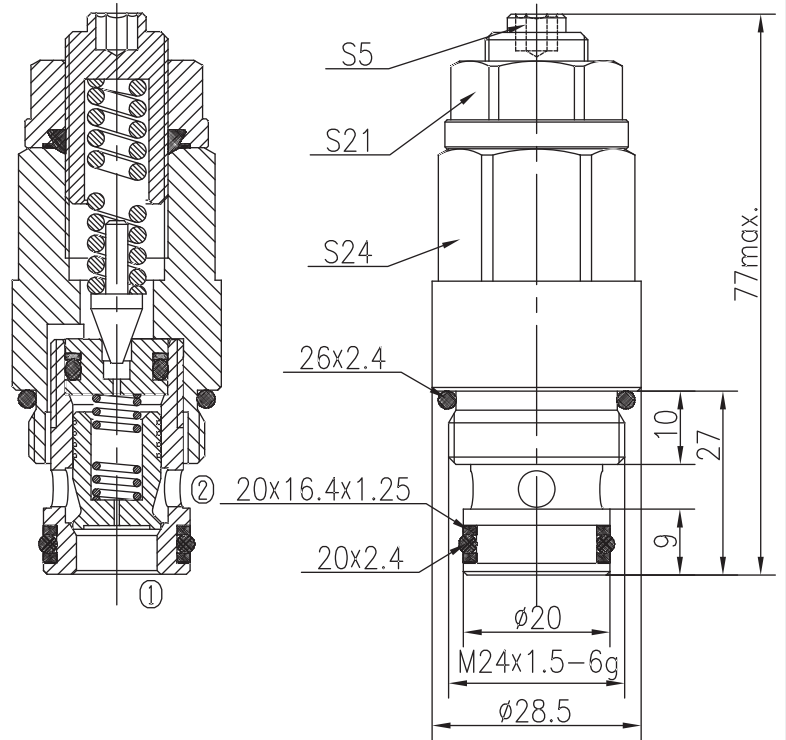
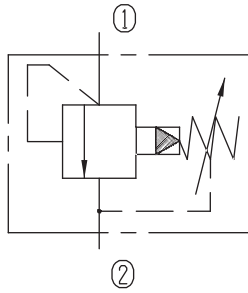

Specifications:

Max working Pressure :	315bar
Flow Max :	60L/min
Internal Leakage :	<30ml/min (85% of Setting Pressure at 30L/min)
Filtration Of Oil :	25µm or better
Temperature :	-30~+100℃ (Standard Buna Seals)
Cavity :	T-2304
Installation torque :	38.7~43.8Nm

The valve blocks flow from ① to ② until 90% pressure is present at ①. With the continued increase pressure on ①, ① to ② began to overflow, until to the spring's maximum pressure.

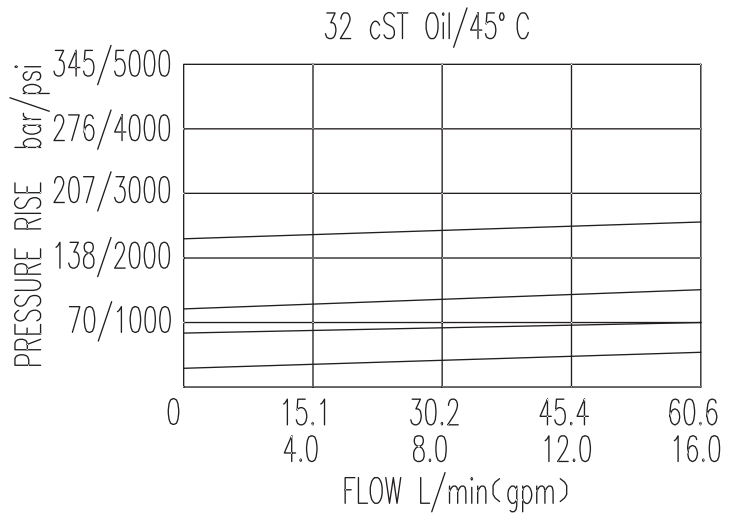

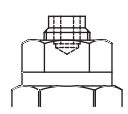
X	ADJUSTMENTS	
03	Looseproof hex. and socket screw	

Y	SPRINGS			
	Press. range bar	Press. increase bar/turn	Standard setting bar	Cracking press. bar
05	1~50	13	35	27
10	40~99	30	70	59
15	60~150	47	120	105
20	130~315	127	175	157