

Pilot-operated Relief Valves (Poppet-type)

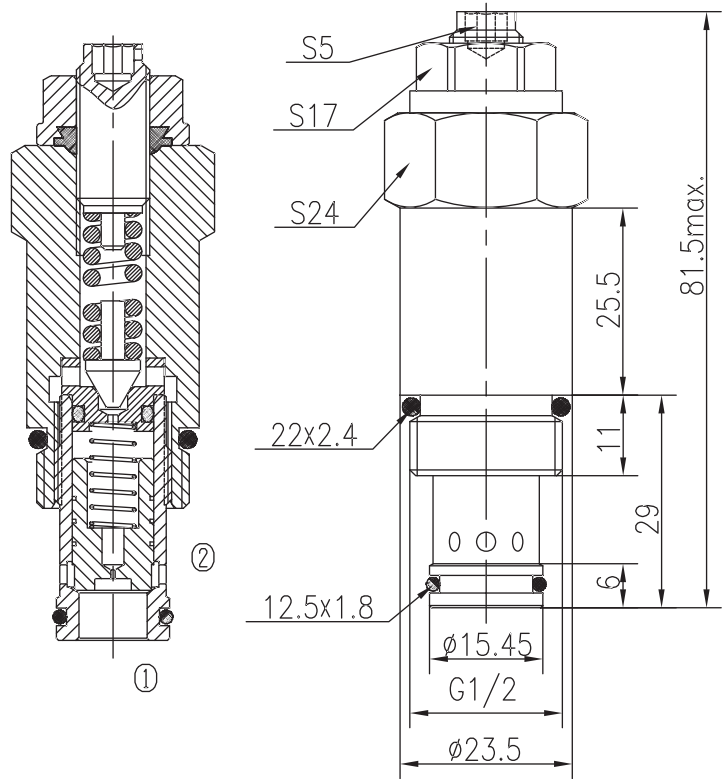

BXYF08-00/X.Y

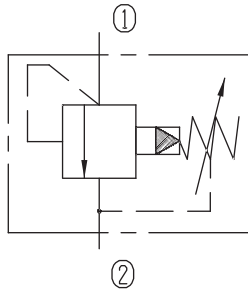

Specifications:

Max working Pressure :	315bar
Flow Max :	50L/min
Internal Leakage :	<30ml/min
(75~85% of Setting Pressure at 30L/min)	
Filtration Of Oil :	25µm or better
Temperature :	-30~+100℃
	(Standard Buna Seals)
Cavity :	T4-S1S
Installation torque :	33.9~36.7Nm
Reverse Cracking Pressure :	1bar

The valve blocks flow from ① to ② until 85% pressure is present at ①. With the continued increase pressure on ①, ② to ① began to overflow, until to the spring's maximum pressure.

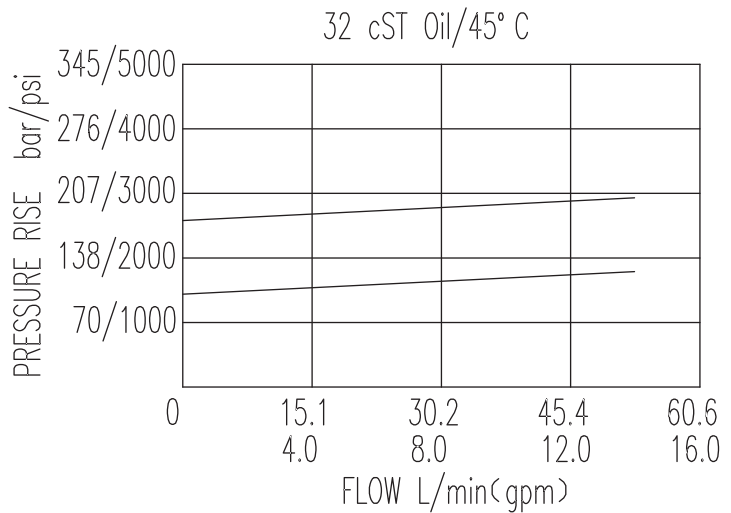

X	ADJUSTMENTS	
03	Looseproof hex. and socket screw	

Y	SPRINGS			
	Press. range bar	Press. increase bar/turn	Standard setting bar	Cracking press. bar
05	1~160		120	98
10	10~315		200	172