

Pilot-operated Pressure Reducing/Relieving Valves

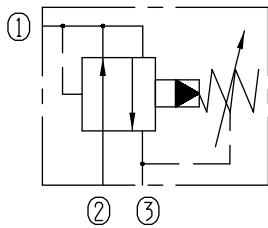

BXJF10-00/X.Y



Specifications:

Max working Pressure :	350bar
Flow Max :	56L/min
Filtration Of Oil :	25μm or better
Temperature :	-30~+100℃ (Standard Buna Seals)
Cavity :	T5-2
Installation torque :	33.9~36.7Nm
Standard Block Model	T5-21*/23*/24*/26*

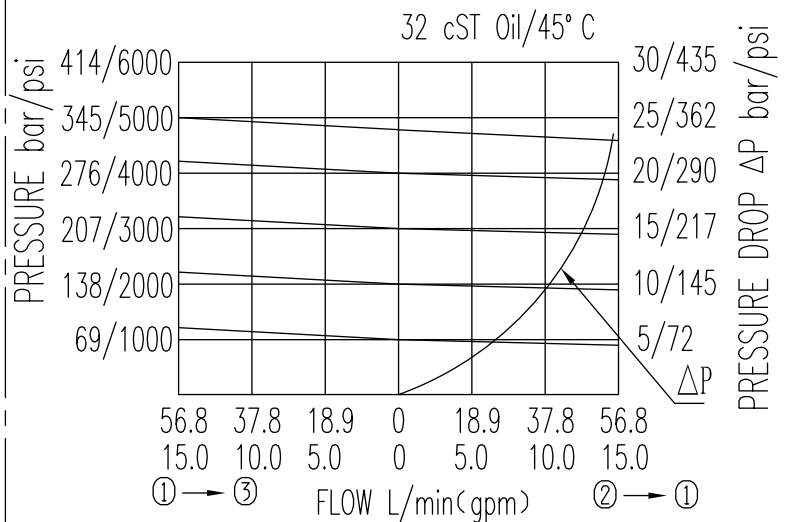
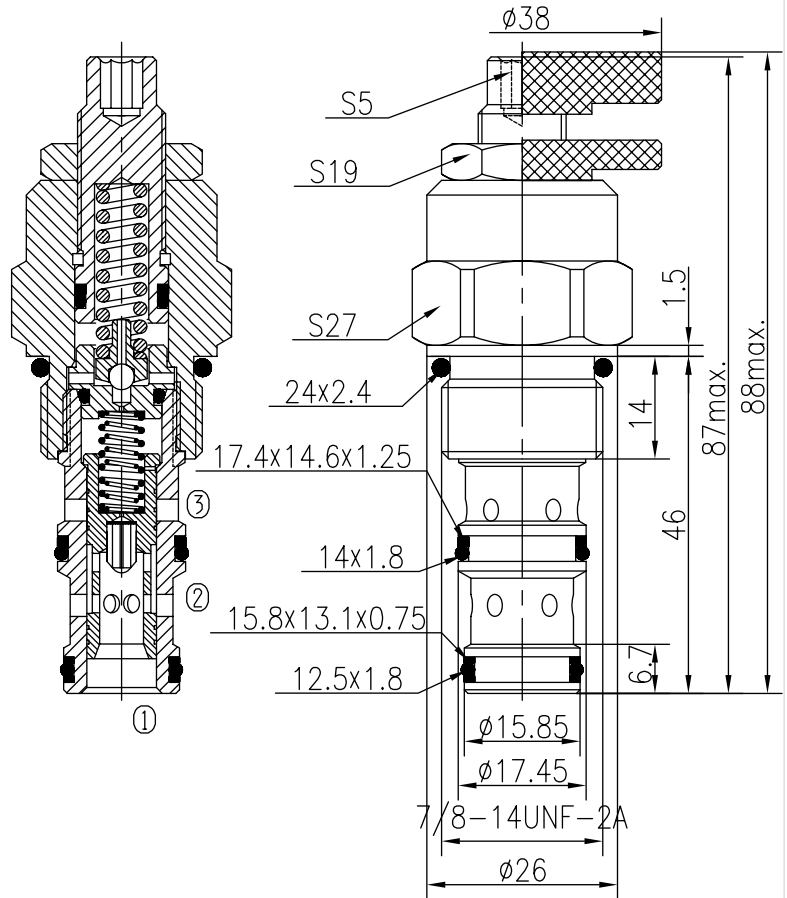

X	ADJUSTMENTS	
03	Leakproof hex. and socket screw	
05	Alum. Knob and Locking Nut	

Y	SPRINGS			
	Press. range bar	Press. increase bar/turn	Standard setting bar	Cracking press. bar
05	7~83	35	80	
10	45~165	83	160	
15	128~320	177	250	