

# Pilot-operated Check Relief Valves (Poppet-type)

BXDYF25-00/X.Y

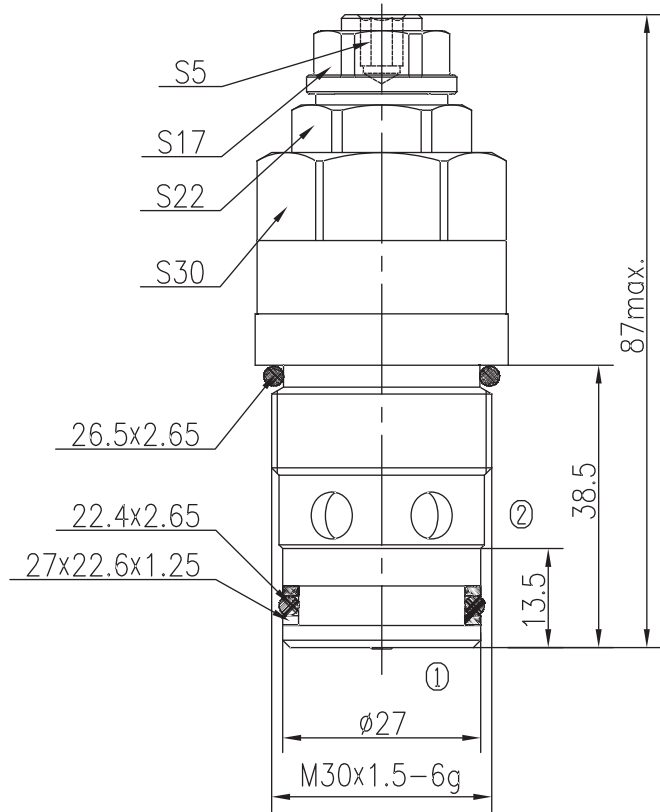
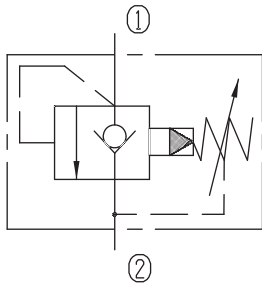

## Specifications:

Max working Pressure :	420bar
Flow Max :	200L/min
Internal Leakage :	<30ml/min (80~90% of Setting Pressure at 30L/min)
Filtration Of Oil :	25μm or better
Temperature :	-30~+100℃ (Standard Buna Seals)
Cavity :	T-2410
Installation torque :	88.4~102Nm
Reverse Cracking Pressure :	1.5bar

The valve blocks flow from ① to ② until 90% pressure is present at ①. With the continued increase pressure on ①, ① to ② began to overflow, until to the spring's maximum pressure.

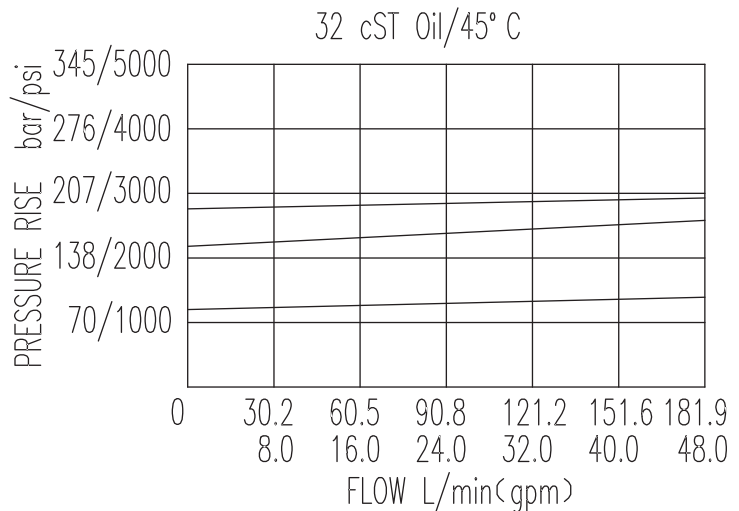

X	ADJUSTMENTS	
03	Looseproof hex. and socket screw	

Y	SPRINGS			
	Press. range bar	Press. increase bar/turn	Standard setting bar	Cracking press. bar
05	10~108	53	100	85
10	20~210	114	160	140
15	60~315	151	200	178
20	100~420	151	350	320