

Pilot-operated Check Relief Valves (Poppet-type)

BXDYF20-02/X.Y

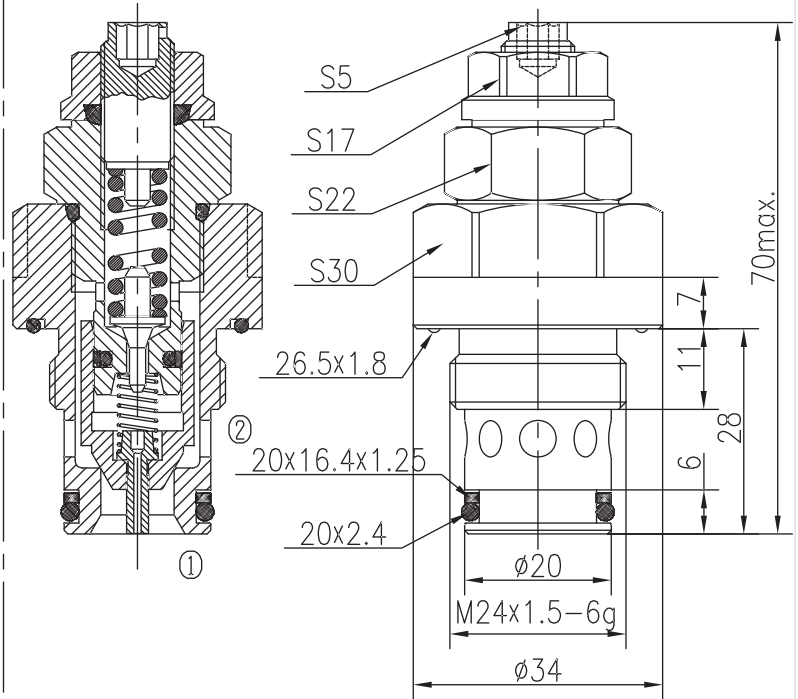
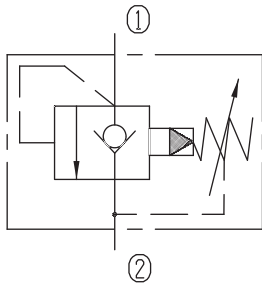

Specifications:

Max working Pressure :	315bar
Flow Max :	113L/min
Internal Leakage :	<30ml/min
(80~90% of Setting Pressure at 30L/min)	
Filtration Of Oil :	25μm or better
Temperature :	-30~+100℃
	(Standard Buna Seals)
Cavity :	T-2404
Installation torque :	38.7~43.8Nm
Reverse Cracking Pressure :	1.5bar

The valve blocks flow from ① to ② until 90% pressure is present at ①. With the continued increase pressure on ①, ① to ② began to overflow, until to the spring's maximum pressure.

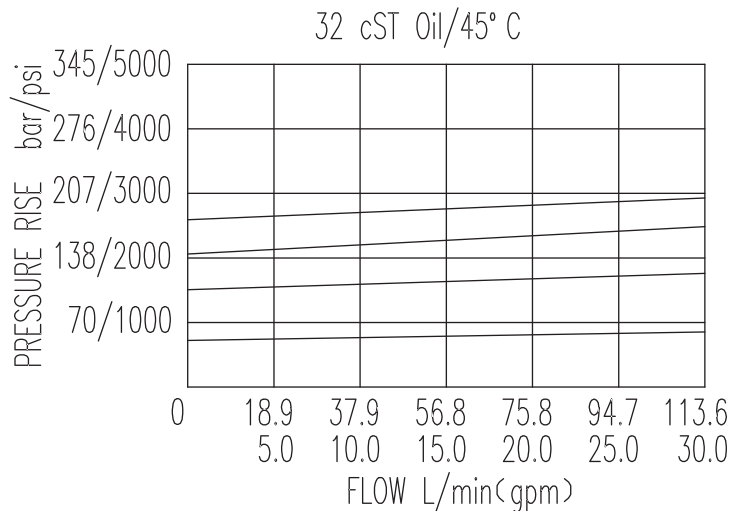

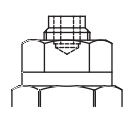
X	ADJUSTMENTS	
03	Looseproof hex. and socket screw	

Y	SPRINGS			
	Press. range bar	Press. increase bar/turn	Standard setting bar	Cracking press. bar
05	10~64	25	60	48
10	55~130	58	120	102
15	110~210	97	160	140
20	160~315	160	200	180