

Pilot-operated Check Relief Valves (Poppet-type)

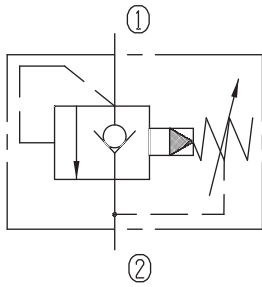

BXDYF20-00/X.Y



Specifications:

Max working Pressure :	315bar
Flow Max :	113L/min
Internal Leakage :	<30ml/min (80~90% of Setting Pressure at 30L/min)
Filtration Of Oil :	25μm or better
Temperature :	-30~+100℃ (Standard Buna Seals)
Cavity :	T-2402
Installation torque :	44.9~50.3Nm
Reverse Cracking Pressure :	1.5bar

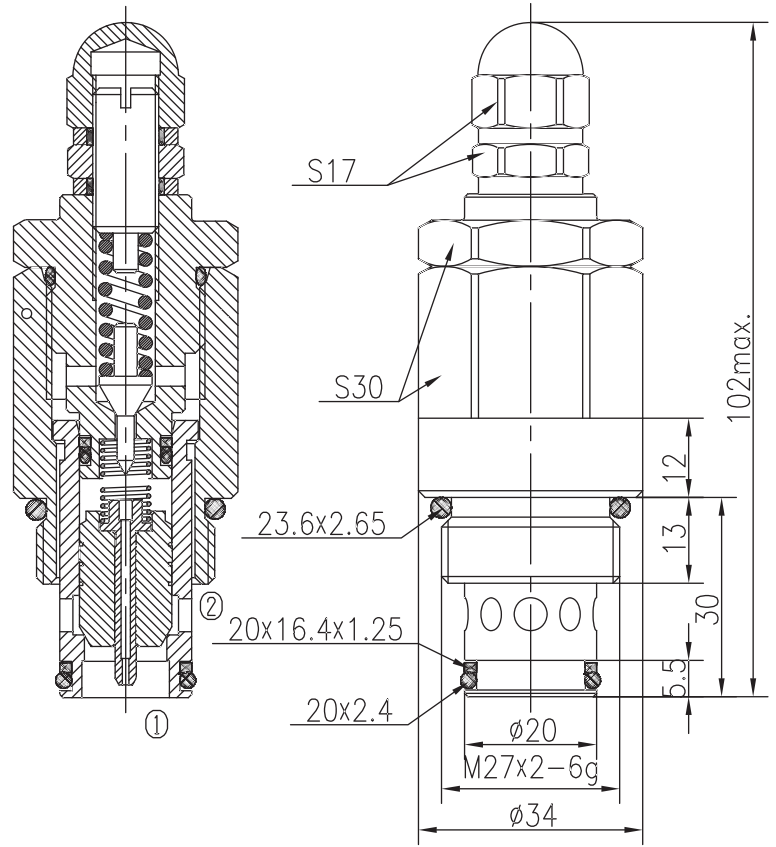

The valve blocks flow from ① to ② until 90% pressure is present at ①. With the continued increase pressure on ①, ① to ② began to overflow, until to the spring's maximum pressure.

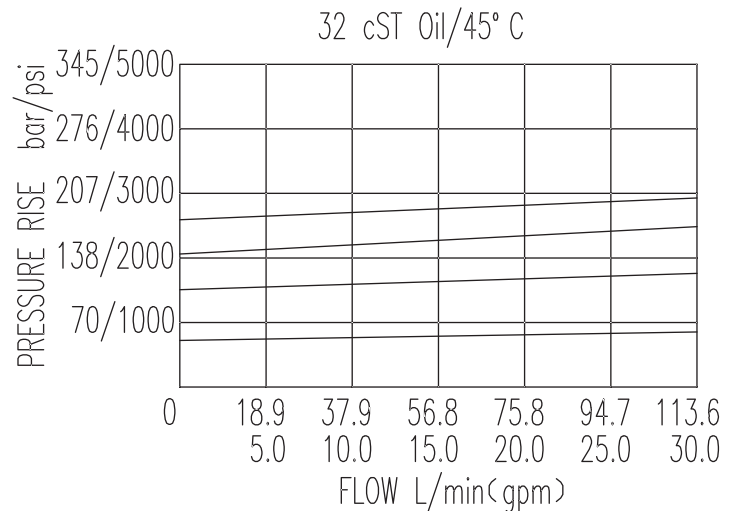

X	ADJUSTMENTS	
03	Top Groove with Cover Nut	

Y	SPRINGS			
	Press. range bar	Press. increase bar/turn	Standard setting bar	Cracking press. bar
05	10~64	22	60	48
10	55~130	51	120	102
15	110~210	85	160	140
20	160~315	121	200	180